

Sandfang DN1000/1200 m/slukrist

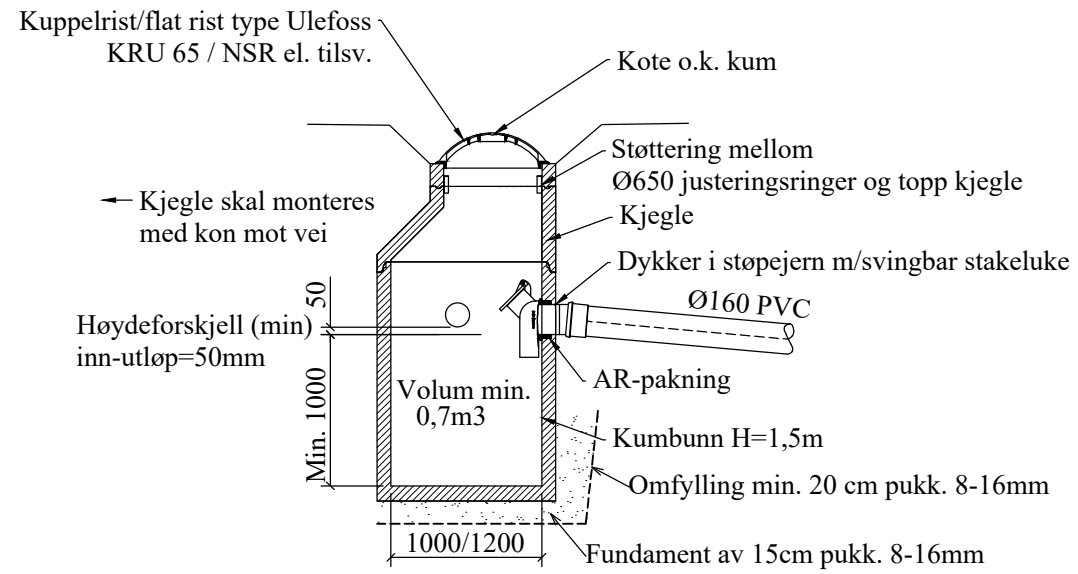

Dim. tilrenning > 25 l/s
Større plasser og veier.

BISLUK DN650

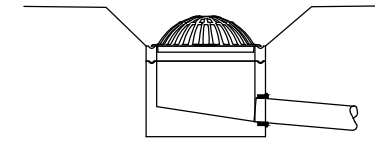

Bisluk benyttes der hvor sandfangskum ikke kan plasseres. Utløpet føres til nærmeste sandfangskum.

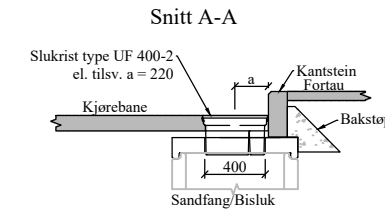

Toppløsning for kantsteinsluk med firkantrist

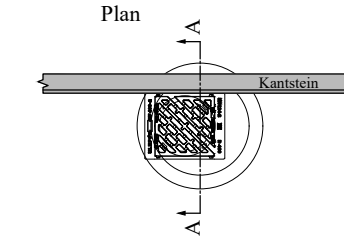

Sandfang DN650m/slukrist

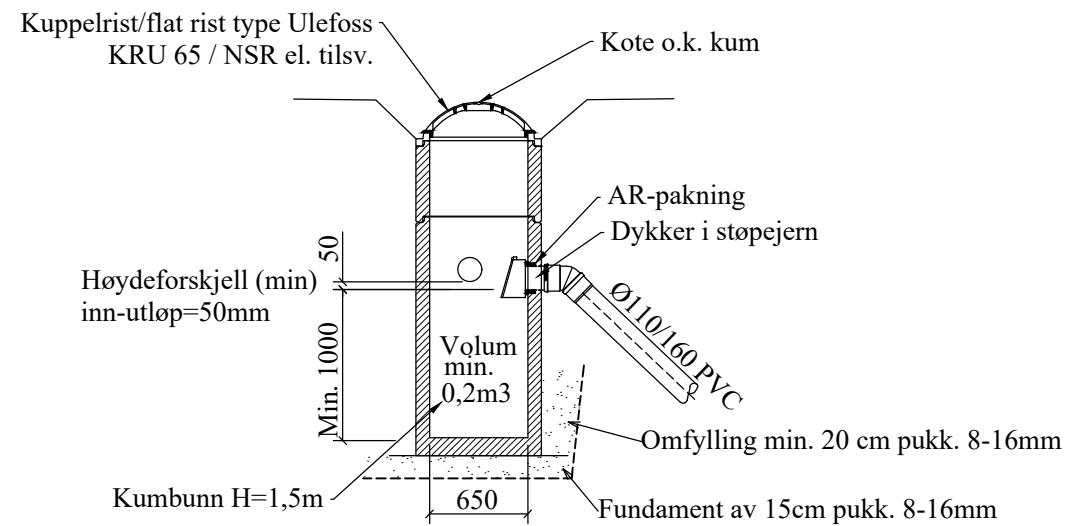

Mindre private veier, langs kantstein og plasser

IFS DN1000 eller tilsv. m/slukrist

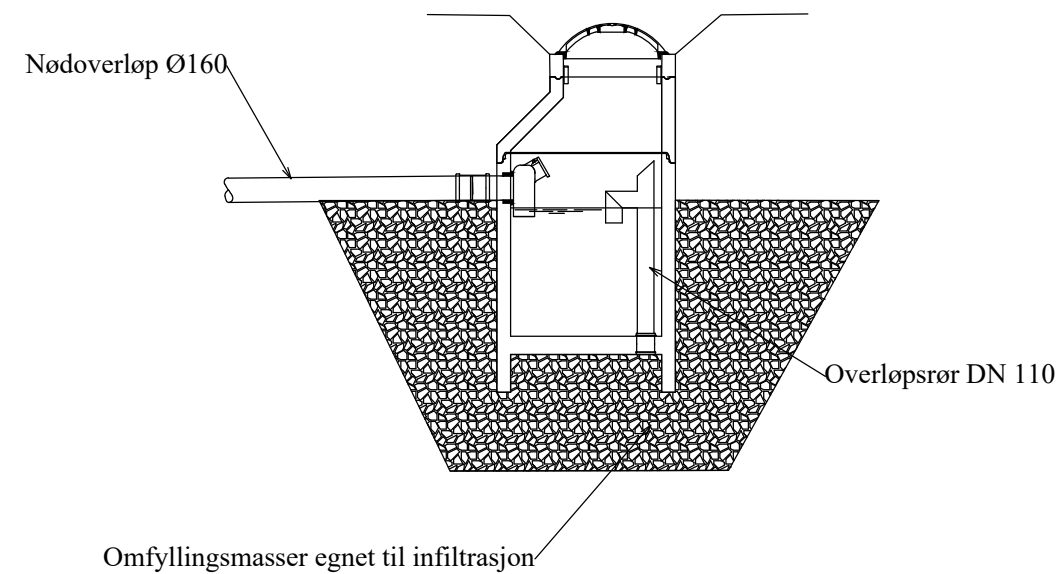

 TØNSBERG KOMMUNE	Tegn.dato: 16.02.2022
	Rev.dato:
	Sign.: VA-CONSULT AS
	Målestokk.: 1:50 (A3)
SANDFANG/BISLUK	Tegn.nr 701